

HIGH CAST Fire Rated Collars

Locally made injection moulded fire collar designed to be cast directly into concrete floor slabs for the provision of plastic pipe penetrations without the need to pre-install sections of pipework, decreasing the amount of time spent on site.



CHC65



CHC100



CHC150

Key Features

- 1 Polypropylene body material gives high moisture resistance and flexural strength
- 2 High grade intumescent formulation for fire performance
- 3 Suitable for slabs up to 250mm
- 4 High profile design saves time on site
- 5 Rubber seal to stop water/debris
- 6 Plastic cap included for protection during installation
- 7 Flexible rubber membrane absorbs pipe movement and vibration

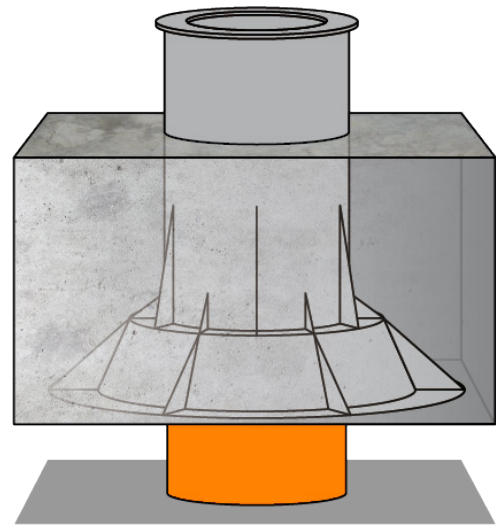

Pipe material	CHC65	CHC100	CHC150
PVC	40, 50 & 65mm (incl fittings)	80, 90 & 100mm (incl fittings)	150mm
HDPE	50, 56, 75mm	100 & 110mm	
PP-R	34, 40, 50, 63 & 75mm	90 & 100mm	-
PP	-	100mm	
RAUPIANO	40 & 75mm	90 & 110mm	
Height	250mm	250mm	250mm
Full diameter (width)	162mm	215mm	305mm
Internal cut-out width (base)	107mm	160mm	235mm

FRL is service specific, ranging up to -/240/240. Contact Trafalgar for more information